

Aug. 7, 1951

C. MARTIN

2,563,477

ELECTRONIC MUSICAL INSTRUMENT

Filed May 1, 1948

2 Sheets-Sheet 1

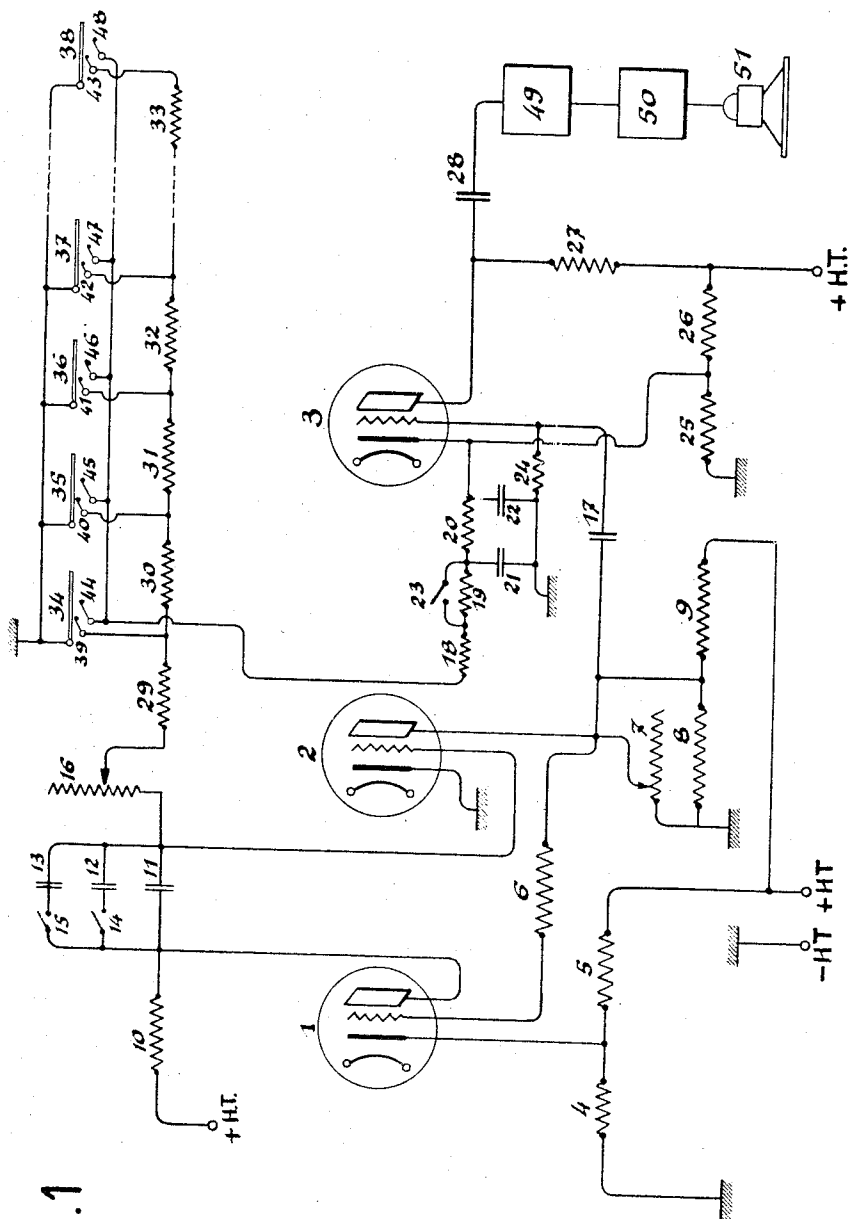

Fig. 1

INVENTOR: CONSTANT MARTIN.
by *Conrad A. Boston*
Attorney.

Aug. 7, 1951

C. MARTIN

2,563,477

ELECTRONIC MUSICAL INSTRUMENT

Filed May 1, 1948

2 Sheets-Sheet 2

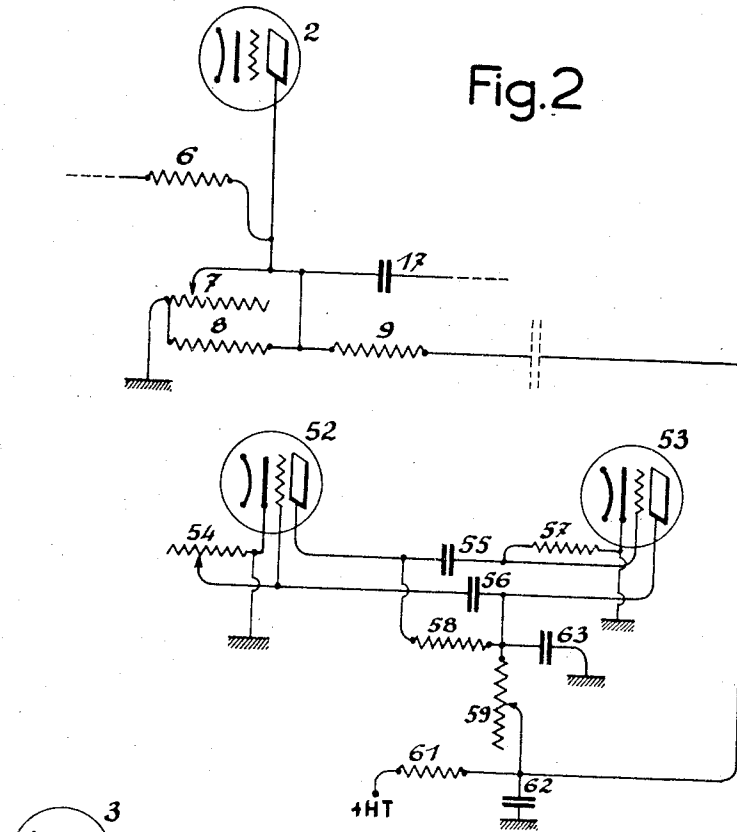

Fig. 2

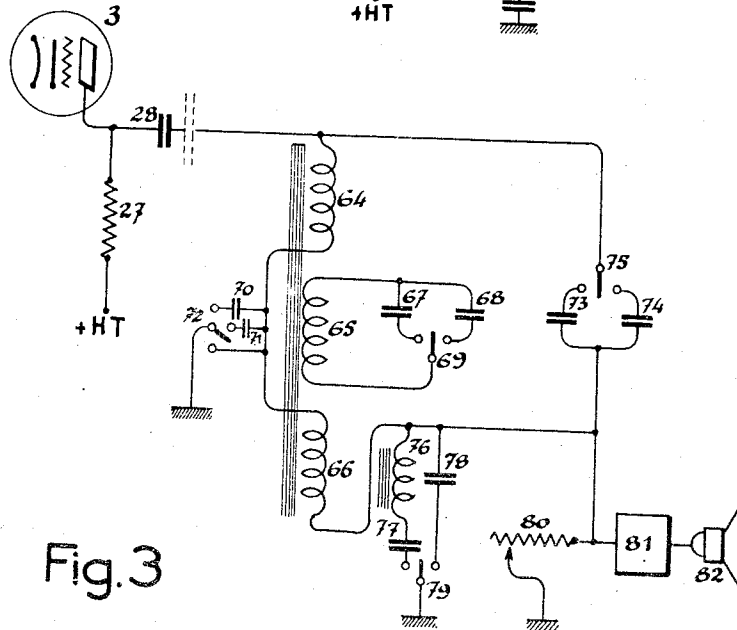

Fig. 3

INVENTOR: CONSTANT MARTIN.
by *Constant Martin*
Attorney.

UNITED STATES PATENT OFFICE

2,563,477

ELECTRONIC MUSICAL INSTRUMENT

Constant Martin, Versailles, France

Application May 1, 1948, Serial No. 24,641
In France May 3, 1947

12 Claims. (Cl. 84—1.25)

1 It is well known that it is possible to provide an electronic musical instrument through the use of an oscillator having two tubes the circuits of which include only resistances and capacities. Such an oscillator or multivibrator as it is termed supplies an oscillation that is very rich in harmonics; this oscillation is amplified, then passed into a loud speaker and the frequency may be varied at the will of the operator, either continuously and progressively from the lowest to the highest note of a scale extending over several octaves, or else through successive steps corresponding with the successive semi-tones of such a scale. In the latter case a key-board generally controls the contacts which are adapted to cause the frequency variations in semi-tones. This frequency variation is obtained either by acting on the capacity of one of the condensers in the oscillator or upon the value of one of the resistances therein as for instance one of the grid resistors.

Such an oscillator however for the purpose contemplated herein offers serious drawbacks. In the most desirable instance of frequency variation through variations in the value of the grid resistance, any alteration in any of the constants of the circuits, for instance in a grid-plate coupling capacitance, will cause a frequency variation in the oscillation which will differ substantially according to whether the oscillator is tuned by said variable grid resistance to a high medium or low frequency.

Now it is particularly important in an electronic musical instrument that any variation in the constants of the oscillator circuit should always cause a similar variation in the oscillation frequency; irrespective of the pitch of the note being sounded. And in particular it is important that if the capacitance of a grid-plate coupling condenser is increased $Q\%$, the frequency of the oscillation should be reduced by $K\%$ and vice versa regardless of the pitch adjustment of the oscillator to a low or high frequency as obtained for example through a variation in the grid resistance. Provided the above condition be fulfilled, the relations between the notes as predetermined once and for all upon construction of the instrument will remain unchanged should for any reason the constants of the oscillator circuit be varied. Moreover if the above-defined condition is met it becomes possible to obtain any predetermined transposition, as for instance to the lower octave of any note sounded on the instrument, by including in parallel with a grid-

2 plate coupling condenser a second condenser of appropriate capacitance.

The above defined condition is not satisfied in the conventional multivibrator.

5 Furthermore the starting of a conventional multivibrator, for instance through the closure of a switch inserted in a grid circuit, gives rise to various transient phenomena: clicking, singing or whistling, and the like, all of which are objectionable in a musical instrument.

10 It is a principal object of the present invention to provide an electronic musical instrument free of the above drawbacks in that it satisfies in particular the above defined condition and enables the emission of musical sound without the occurrence of the undesirable above-mentioned effects.

15 For this purpose, it is an object of the invention to provide a dual tube oscillator including resistances and capacitors associated with a coupling system which includes a third tube, the whole assembly being connected through filter means with an amplifier followed by a loud-speaker. A principal feature of said oscillator is that it only comprises resistances and a single condenser which provides for the coupling between the plate of the first tube and the grid of the second tube. Coupling between the plate of the second tube and the grid of the first tube is effected through a resistance. A discharge resistance coupling the grid of the second tube with earth is adapted to be varied either progressively or by successive increments by means of taps connected into the circuit by means of switches each controlled for instance from a key of the keyboard. The frequency of the oscillation is thus made practically to depend on the time constant of the discharge circuit for the coupling condenser. The various circuits of the oscillator include no other condenser than the above mentioned coupling condenser, and as a result the normal and stable oscillatory condition is established an extremely short time after the closure of a switch inserted for instance in a grid circuit of either one of the oscillator tubes, whereby any tendency to singing is suppressed. The click or bang which is liable to occur upon closure or opening of the switch is moreover eliminated as described hereinafter in greater detail by means of a tube coupling system with which the oscillator is associated.

Further objects or features of the device according to the invention are as follows:

25 The cathode of the second tube is earthed. The cathode of the first tube connected on one hand

3

with earth through a low resistance and on the other hand with the terminal of the high voltage source through a resistance of higher value is thus brought to a positive potential of moderate value.

Similarly the plate of the second tube is brought to a moderate positive potential by means of a potentiometer system arranged between the positive terminal of the high voltage source and earth.

The plate of the first tube is connected with the positive terminal of the high voltage through a resistance. Adjustment of the respective voltages of the cathode of the first tube and the plate of the second tube is so effected as to cause the operation of the oscillator to be satisfactory for given tube characteristics.

Subsequent to the oscillator constructed according to the above general lines, the invention further comprises a coupling tube system having the following characteristic features:

The grid of said coupling tube is coupled with the plate of the second oscillator tube for instance through a low capacitance. The cathode of the coupling tube is connected on one hand with a point which is at positive potential with respect to earth, whereby the difference in potential between said point and earth is sufficient to block the tube, and on the other hand with a resistance and capacitance network having a predetermined time constant and connected with earth with the interposal of a switch. The adjustment is so effected that closure of said switch is adapted after an accurately predetermined delay to un-block the coupling tube which then operates as an amplifier. The amplified oscillations derived from the oscillations supplied to the grid of said tube are then recovered in the plate circuit thereof.

In brief the device operates as follows:

A mechanical member such as a key or the like is adapted successively and as a result of a common actuating movement, first to close a switch to start the oscillator at a given frequency, then close a switch for firing or de-blocking the coupling tube, said switch being interposed in the cathode circuit of said tube. The oscillation is thus caused to be produced before the coupling tube has had time to act and the effect of this coupling tube is furthermore delayed a time proportionate with the time constant of the cathode circuit of said latter tube. The cathode circuit time constant may be selected barely sufficient to eliminate the clapping upon starting the oscillator, this meaning that a very rapid musical note is emitted, or further it may be selected so that the emission of said note will be effected with the desired slowness.

Following the oscillator associated with the coupling system as just described there are mounted one or more filters and thereafter an amplifier and a loud-speaker.

The features of the device of the invention are illustrated in detail in the accompanying drawings with reference to which the ensuing description is made.

Fig. 1 is a wiring diagram illustrating a device according to the invention.

Fig. 2 is a wiring diagram of a periodical modulator associated with the device of the invention for the production of a vibrato effect.

Fig. 3 is a wiring diagram illustrating a filter assembly adapted for connection between the coupling system and the amplifier.

The above figures are given merely by way of example and the devices or elements shown

4

therein are not restrictive of the scope of the invention which it will be understood also includes any operative modifications and alternative conforming to the spirit thereof.

According to Fig. 1 two tubes 1 and 2 are mounted as oscillators and the circuits thereof only include resistances and a condenser 11. This condenser however may have connected across its electrodes a second condenser 12 upon closure of a switch 14 and also a third condenser 13 upon closure of a switch 15. The capacities selected for the condensers 12 and 13 may be such for instance that, if the oscillator is adjusted to a predetermined tone, the introduction of the condenser 12 in parallel with 11 through closure of the switch 14 is operative to transpose said note an octave down therefrom, while the shunting of the condenser 11 with the condenser 13 through closure of the switch 15 will transpose the same note two octaves down.

The grid of the tube 2 is connected through an adjustable resistance 16 with a series of resistances 29, 30, 31, 32 . . . 33. The resistances in said series are so selected as to permit of adjusting the oscillations of the tubes 1 and 2 to any of the notes of a scale. For this purpose each junction between consecutive resistances is connected with a contact member such as 39, 40, 41, 42 . . . 43, each of which may be contacted by a cooperating contact member 34, 35, 36, 37 . . . 38 respectively, all of the last-mentioned of contact members being connected in common with ground. The valves selected for the resistances in said series are such: that the contact of contact member 34 and contact member 39 will adjust the oscillator to the highest note of the scale, the contact of contact member 35 and contact member 40 will adjust the oscillator upon the note just beneath the highest note; the contact of contact member 36 with contact member 41 will adjust the oscillator upon the note just below the preceding one and so on, down to the lowermost note. The variable resistance 16 arranged at the head of the series of resistances 29, 30, 31, etc. . . . serves to compensate for any possible discord in the instrument, as for instance, in the case where the tubes used at the time when an accurate adjustment of the resistances 29, 30, 31, etc. . . . has been effected are replaced by other tubes having slightly different characteristics.

Moreover the plate of the tube 1 is connected with high voltage through the resistance 10. The grid of the tube 1 is connected through the resistance 6 with the plate of the tube 2 which in turn is supplied from the resistance network 7, 8 and 9. The resistance 7 is a variable resistance and its adjustment around a certain average value will effect an increase or a decrease in the oscillation frequency. Adjustment of the resistance 7 is used to displace at will the entire spread covered by the instrument a few tones up or down from a given average set of values. The cathode of the tube 1 is brought to a slightly positive potential by means of the resistances 4 and 5 interposed between the positive terminal of the high voltage source and ground.

A condenser 17 of low value connects the plate of the tube 2 with the grid of the tube 3 which in turn is connected with earth through the resistance 24. The cathode of the tube 3 is brought to a positive potential through the resistances 25 and 26 connected between high voltage and earth. A resistance network 18, 19, 20 connects

said cathode with contact members 44, 45, 46, 47 . . . 48.

The condensers 21 and 22 are respectively arranged between cathode and earth and between the common junction of the resistances 19 and 20 and earth. A switch 23 may selectively short-circuit the resistance 19. The plate of the tube 3 supplied with voltage through the resistance 27 is connected with the input of a filter-unit 49 the output of which is followed by an amplifier 50 supplying a loud-speaker 51.

Each of the contact members 34, 35, 36, 37 . . . 38 is operatively connected with a control member such for instance as a key forming part of a key-board. As the key relating to the part 34 is depressed this contact first engages the contact 39, then the contact 44. Similarly upon depression of the key relating to contact 35 said contact first engages the contact 40 then the contact 45. And in the same way: 36 engages 41 then 46; 37 engages 42 then 47; and so on. All of the contacts such as 44, 45, 46, 47, etc. . . to 48 are as previously stated connected with the cathode circuit of the tube 3.

The device described above operates as follows:

If the key drivingly connected with the contact 34 for instance is depressed, the contact 34 will first engage the contact 39 thereby earthing the grid of the tube 2 through the resistances 16 and 29. The oscillator including the tubes 1 and 2 is then started and its musical oscillation frequency is, say that corresponding to the note C6. Since the cathode of the tube 3 is brought by means of the resistances 25 and 26 to a high enough potential to prevent transmission to the grid of said tube, the loud-speaker 51 remains silent. However when the contact 34 a very short time after having engaged the contact 39 further engages the contact 44 the cathode of the tube 3 is earthed through the resistances 18, 19, 20. The potential drop between cathode and earth is at once reduced and stabilized at a value which allows the tube 3 to amplify the oscillation transmitted to its grid. This amplified oscillation passes through the filtering system 49 in which it is subjected to certain modifications effective to impart to the note the desired quality of timbre and it is then subjected to additional amplification in the amplifier 50 and finally actuates the loud-speaker 51 which will then sound the note C6 with the desired volume and timbre.

The time during which the cathode potential passes from the cut-off value to the value allowing normal operation depends on the capacities of condensers 21 and 22 and the values of resistances 18, 19, 20. A switch 23 may selectively be caused to short-circuit the resistance 19 thereby reducing this delay.

By suitably selecting the resistances 18, 19, 20 and condensers 21 and 22 there may for instance be obtained two different conditions for the manner in which the firing or unblocking of the tube 3 is caused to occur, according to whether switch 23 is open or closed. One of said conditions produces an impact of percussion effect while the other one produces a very gradual start.

The above discussion relating to the depression of a key controlling the contact 34 may be repeated in connection with the depression of any of the keys controlling the contacts 35, 36, 37 . . . 38. Thus for instance shifting of contact 35 towards contact 40 and contact 45 will sound B5, shifting of contact 36 toward contact

41 and contact 46 will sound A sharp 5, shifting of contact 37 toward contact 42 and contact 47 will sound A5 and so on and shifting of contact 38 towards contact 43 and contact 48 will sound the lowermost note in the scale.

Fig. 2 illustrates an example of a periodical modulator adapted to cyclically vary the plate voltage of one of the oscillator-tubes of the above described device thereby producing a vibrato effect.

To simplify the drawing the plate-circuit of the tube 2 which is one of the oscillator tubes of the previously described device has alone been shown. Two tubes 52 and 53 are mounted as resistance-capacity oscillators and the high voltage supply for this oscillator is tapped off the plate-circuit of the tube 2 through the resistance 61.

The resistances 54, 57, 58, 59 and condensers 55, 56, 62 and 63 are so selected that the oscillating frequency of the modulator system will be in the order of a few cycles per second. This oscillation will produce periodic vibrations in the voltage drop across the resistance 61, which will be expressed as periodic variations in the frequency of the oscillations generated by the tubes 1 and 2 of the previously described device, thereby yielding a vibrato effect.

Frequency of the modulator is adjusted for instance through the variable resistance 54 and the amplitude of the vibrato is adjusted with the variable resistance 59 acting on the output of the tubes 52 and 53.

Fig. 3 illustrates a filter system for association with the previously described device as generally exemplified in Fig. 1.

It essentially comprises a transformer having three windings 64, 65, 66. The windings 64 and 66 are arranged on both sides of winding 65 and are in series. This transformer is arranged between the plate of the tube 3 partially shown in this figure and which is the coupling tube between the device illustrated in Fig. 1 and the input to the amplifier 81.

The switch 79 selectively connects between earth and the end of the winding 66, a condenser 78 or a network including an inductance 76 and a condenser 77.

The switches 69 and 75 selectively connect the condensers 67 and 68 across the winding 69 while the switch 75 may selectively connect the condensers 73 and 74 across the free-ends of the series windings 64 and 66.

A switch 72 selectively enables the junction of the series windings 64 and 66 to be earthed either directly or through the condensers 70 and 71.

A variable resistance 80 is arranged in shunt across the input to the amplifier 81 to control the volume and possibly the timbre of the sound produced. The entire arrangement described above in connection with Fig. 3 provides a complex filter means enabling multiple combinations adapted to selectively modify through the actuation of the switches 72, 69, 75, 69 the timbre of the note sounded by the instrument.

Inasmuch as various modifications may be made in the above-described embodiments and that the invention may be practically carried out in a wide range of apparently greatly different forms without exceeding the scope thereof as more particularly defined in the ensuing claims it is to be distinctly understood that all of the specific details given in the above description and/or illustrated in the accompanying drawings have been given merely for purposes of exemplification and not for restricting the scope of the invention,

7

What I claim as my invention and desire to secure by Letters Patent is:

1. In an electronic musical instrument in combination with an oscillator unit, a tube-coupling unit, a filter unit, an amplifier unit and a loud-speaker mounted in sequence from the output of said oscillator, said oscillator unit comprising a first tube and a second tube having its grid coupled through a capacity with the anode of said first tube and having its anode coupled through a resistance with the grid of said first tube, variable grid-resistance means for said second tube to vary the output frequency thereof, and supply means for said oscillator.

2. In an electronic musical instrument in combination with an oscillator, a tube-coupling unit, a filter unit, an amplifier unit and a loud-speaker mounted in operative sequence from the output of said oscillator, said oscillator comprising a first tube and a second tube having its grid capacity-coupled with the anode of said first tube and its anode resistance-coupled with the grid of said first tube, a progressively-variable grid resistance connecting the grid of said second tube with ground to vary the output frequency of said oscillator, and supply means for said units.

3. In an electronic musical instrument in combination with an oscillator unit, a tube-coupling unit, a filter unit, an amplifier unit and a loud-speaker mounted in operative sequence from the output of said oscillator, said oscillator comprising a first tube and a second tube having resistance-coupled with the grid of said first tube, and a multi-tapped resistance connecting the grid of said second tube with ground and key-actuated contact means to selectively place in and out of circuit any desired portion of said multi-tapped resistance to vary the output frequency of said oscillator, and supply means for said units.

4. In an electronic musical instrument in combination with an oscillator unit, a tube-coupling unit, a filter unit, an amplifier unit and a loud-speaker mounted in operative sequence from the output of said oscillator, supply means for said units, said oscillator comprising a first tube and a second tube having its grid capacity-coupled with the anode of said first tube and its anode resistance-coupled with the grid of said first tube, adjustable grid resistance means for said second tube to vary the output frequency of said oscillator, the cathode of said second tube being grounded, voltage-divider means connected with the cathode of said first tube to bring said cathode to a moderate positive potential and voltage divider means to bring the anode of said second tube to a moderate positive potential.

5. In an electronic musical instrument in combination with an oscillator unit, a tube coupling unit, a filter unit, an amplifier unit and a loud-speaker, supply means for said units, said oscillator comprising a first tube and a second tube having its grid capacity-coupled with the anode of said first tube and its anode resistance-coupled with the grid of said first tube, adjustable grid resistance means for said second tube to vary the output frequency of said oscillator, the cathode of said second tube being grounded, the cathode of said first tube being connected with ground through a lower resistor and with high voltage through a higher resistor to bring said cathode to a moderate positive potential, and the anode of said second tube being connected between high voltage and ground through a potentiometer means to bring said anode to a moderate positive potential, said resistors being so selected and said

8

potentiometer so adjusted as to bring said first tube cathode and said second tube anode respectively to moderate positive potentials in correlation with the respective characteristics of said tubes.

6. The arrangement of claim 1 wherein said capacity-coupling between the anode of said first tube and the grid of said second tube includes a first condenser and at least one additional condenser selectively connectable in parallel with said first condenser, so selected as to cause said oscillator to produce at least one additional frequency having a predetermined constant relation with respect to the basic frequency produced thereby as determined by said variable grid-resistance.

7. In an electronic musical instrument in combination with an oscillator unit, a tube-coupling unit, a filter unit, an amplifier unit and a loud-speaker mounted in operative sequence from the output of said oscillator unit, said oscillator unit comprising a variable resistance means in the grid circuit of the output tube thereof to vary the output frequency of said oscillator, and said coupling unit comprising a tube having its grid coupled with the anode of said oscillator output tube and its cathode connected with a point at positive potential normally sufficient to block said coupling tube and a resistance-capacitance delay network having a predetermined time constant connecting said cathode with ground with the interposal of a normally open cut-off switch, closure of said switch being operative to ground said cathode thus firing said tube after a delay as determined by said delay network, said tube then operating to pass the oscillations from said oscillator to said filter unit.

8. In an electronic musical instrument in combination an oscillator unit having key means to operate said oscillator at a desired one of a plurality of output frequencies, a coupling unit at the output of said oscillator and an output circuit including filtering, amplifying, and loud-speaker means from said coupling unit, said coupling unit including a tube adapted when unblocked to operate as an amplifier for said oscillator output frequency, means normally blocking said coupling tube and means including a delay network and switch means for un-blocking said tube with a predetermined delay after closure of said switch means, said switch means being adapted to be closed upon operation of any one of said keys, whereby upon operation of any one of said keys oscillations are allowed to pass into said output circuit only after the disappearance of any transient phenomena in said oscillator, and means for varying the time constant of said delay circuit.

9. In an electronic musical instrument in combination: an oscillator unit comprising a first tube, a second tube having its grid capacity coupled with the anode of said first tube and its anode resistance-coupled with the grid of said first tube, and a multi-tapped resistance means connecting the grid of said second tube with ground and key-operated contact means to selectively place in and out of circuit any desired portion of said multi-tapped resistance means to vary the output frequency of said oscillator, a coupling unit comprising a tube having its grid coupled with the anode of said second oscillator tube to amplify when not blocked the output frequency of said oscillator, and an output circuit including a filter means, an amplifier and a loud-speaker connected with the anode-circuit of said

9

coupler tube, biasing means normally blocking said coupler tube, and means to un-block said tube comprising a delay network and switch means, said switch means being adapted to be closed upon operation and any one of said keys 5 not before the actuation by said key of said oscillator contacts, and means to vary the time constant of said delay network.

10. In the electronic musical instrument of claim 1, means associated with one of said oscillator tubes to periodically modify the anode voltage thereof at a rate of a few cycles per second, and means to alter the rate and amplitude of said voltage variations. 10

11. In the electronic musical instrument of claim 1, vibrato means comprising an auxiliary pair of oscillator tubes having resistance-capacitance oscillatory circuits therein for producing an auxiliary very low frequency of a few cycles per second, variable resistance means to adjust the rate and amplitude of said auxiliary frequency, said auxiliary oscillator tubes being supplied in high voltage in parallel with the anode of one of said first-mentioned oscillator tubes whereby said auxiliary very low frequency is adapted to produce corresponding variations in the anode voltage of said one tube. 15 20 25

12. In an electronic musical instrument in combination, an oscillator including resistance-capacitance networks in the tube circuits thereof, a coupling means for said oscillator including a normally blocked amplifier tube adapted to be un-blocked a predetermined time after said oscil-

10

lator is operated, filter means in the output of said coupling tube and amplifier and loud-speaker means in the output of said filter means, said filter means comprising a transformer having three windings including two series-connected outer windings and an intermediate winding, the free end of one of said outer windings being connected with the anode of said coupling tube and the free end of the other outer winding being connected with the input to said amplifier, means for selectively grounding said last-mentioned end through one of at least two inductance-capacitance networks, means for selectively interconnecting both ends of said intermediate winding through one of at least two capacitors, means for selectively interconnecting both said free ends of said outer windings through one of at least two capacitors, and means for selectively grounding the common connection of both said outer winding through one of at least two capacitors or through a direct ground connection, and a variable resistor grounding said amplifier input.

CONSTANT MARTIN.

REFERENCES CITED

The following references are of record in the file of this patent:

UNITED STATES PATENTS

Number	Name	Date
2,169,762	Kaye	Aug. 15, 1939
2,233,258	Hammond et al.	Feb. 23, 1941