

## Data Sheet



### SCA121T DUAL AXIS INCLINOMETER MODULES

The SCA121T Series contain 3D-MEMS-based dual axis inclinometer modules that provide instrumentation grade performance for leveling applications in harsh environment. The measuring axes of the sensing elements are parallel to the mounting plane and orthogonal to each other. Low temperature dependency, high resolution and low noise, together with a robust sensing element design, make the SCA121T the ideal choice for leveling instruments. The VTI inclinometers are insensitive to vibration, due to their over damped sensing elements, and can withstand mechanical shocks of up to 20000 g.

#### Features

- Dual axis inclination measurement (X and Y)
- Measuring ranges  $\pm 30^\circ$  and  $\pm 90^\circ$
- 0.0035° resolution (10 Hz BW, analog output)
- Sensing element controlled over damped frequency response (-3dB 18Hz)
- Robust design, high shock durability (20000g)
- High stability over temperature and time
- Single +5 V supply and unregulated 7...35V supply
- RoHS compliant

#### Applications

- Platform leveling and stabilization
- 360° vertical orientation measurement
- Leveling instruments
- Cabin leveling
- Solar panel control systems



#### IS-LINE GmbH

Edisonstr. 16  
85716 Unterschleißheim  
Tel.: +49 (89) 374 288 87 - 0  
Fax: +49 (89) 374 288 87 - 99  
E-Mail: [info@is-line.de](mailto:info@is-line.de)  
[www.is-line.de](http://www.is-line.de)

## TABLE OF CONTENTS

<b>SCA121T Dual Axis Inclinometer modules</b> .....	<b>1</b>
<b>Features</b> .....	<b>1</b>
<b>Table of Contents</b> .....	<b>2</b>
<b>1 Electrical Specifications</b> .....	<b>3</b>
<b>1.1 Absolute Maximum Ratings</b> .....	<b>3</b>
<b>1.2 Performance Characteristics</b> .....	<b>3</b>
<b>1.3 Electrical Characteristics</b> .....	<b>4</b>
<b>1.4 Electrical Connection</b> .....	<b>4</b>
<b>2 Functional Description</b> .....	<b>4</b>
<b>2.1 Measuring Directions</b> .....	<b>4</b>
<b>2.2 Voltage to Angle Conversion</b> .....	<b>4</b>
<b>2.3 Ratiometric Output</b> .....	<b>5</b>
<b>3 Mechanical Specifications</b> .....	<b>5</b>
<b>3.1 Sensor dimensions</b> .....	<b>6</b>

## 1 Electrical Specifications

The SCA121T product family comprises three versions, the SCA121T-D03, the SCA121T-D05 and the SCA121T-D07 that differs in measurement range and supply voltage. The product version specific performance specifications are listed in the table SCA121T performance characteristics below.

### 1.1 Absolute Maximum Ratings

Supply voltage SCA121T-D05(V <sub>DD</sub> )	Regulated -0.3 V to +5.5V
Supply voltage SCA121T-D03 and D07	Unregulated -0.3 V to +35V
Voltage at input / output pins	-0.3V to 5.3
Storage temperature	-55°C to +85°C
Operating temperature	-40°C to +85°C
Mechanical shock	Drop from 1 meter onto a concrete surface (20000g). Powered or non-powered

### 1.2 Performance Characteristics

Parameter	Condition	SCA121T-D03	SCA121T-D05	SCA121T-D07	Units
Measuring range	Nominal	±90	±90	±30	°
		±1	±1	±0.5	g
Supply Voltage		7...35	5±0.25	7...35	V
Offset (Output at 0g)		2.5	V <sub>dd</sub> /2	2.5	V
Offset calibration error	Max deviation	±1.5	±1.5	±1.5	°
Sensitivity		2	2	4	V/g
	between 0...1° <sup>(1)</sup>	35	35	70	mV/°
Sensitivity calibration error		±1.5	±1.5	±1.5	%
Offset temperature dependency	-25...85°C	±1	±1	±1	°
	0...70°C	±0.5	±0.5	±0.5	°
Sensitivity temperature dependency	-25...85°C	-1.5...+0.5	-1.5...+0.5	-1.5...+0.5	%
	0...70°C	-0.8...+0.3	-0.8...+0.3	-0.8...+0.3	%
Typical non-linearity	Measuring range			±0.57	°
Frequency response	-3dB LP <sup>(2)</sup>	8-28	8-28	8-28	Hz
Ratiometric error	V <sub>dd</sub> = 4.75...5.25V		±2		%
Cross-axis sensitivity	Max.	4	4	4	%

Note 1. The angle output has SIN curve relationship to voltage output.

Note 2. The frequency response is determined by the sensing element's internal gas damping.

### 1.3 Electrical Characteristics

Parameter	Condition	Min.	Typ	Max.	Units
Current consumption	No load		5	8	mA
Operating temperature		-40		+85	°C
Analog resistive output load	Vout to Vdd or GND	10			kOhm
Analog capacitive output load	Vout to Vdd or GND			20	nF
Start-up delay	Reset and parity check			10	ms

### 1.4 Electrical Connection

Wire Color	Name	Function
Blue	GND	Ground
Red	Vdd	Power supply
Yellow	Out X	X-axis output
Green	Out Y	Y-axis output
White	NC	Not Connected

## 2 Functional Description

### 2.1 Measuring Directions

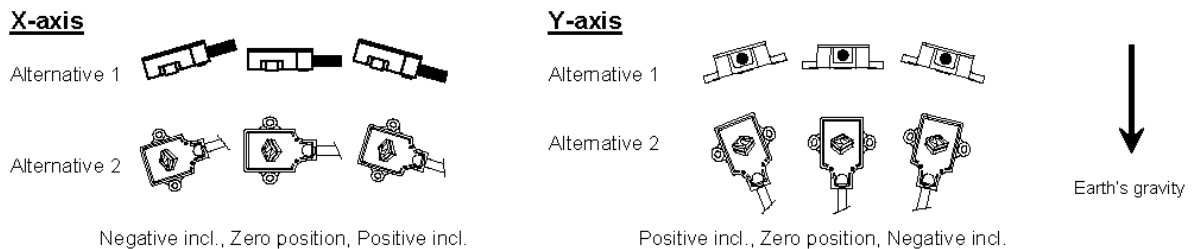

**Figure 1.** The measuring directions of the SCA121T

### 2.2 Voltage to Angle Conversion

Analog output can be transferred to angle using the following equation for conversion:

$$\alpha = \arcsin\left(\frac{V_{out} - Offset}{Sensitivity}\right)$$

Where: Offset = output of the device at 0° inclination position, Sensitivity is the sensitivity of the device and  $V_{Dout}$  is the output of the SCA121T. The nominal offset is 2.5 V and the sensitivity is 4 V/g for the SCA121T-D07 and 2 V/g for the SCA121T-D03 and SCA121T-D05.

Angles close to 0° inclination can be estimated quite accurately with straight line conversion but for the best possible accuracy, arcsine conversion is recommended to be used. The following table shows the angle measurement error if straight line conversion is used.

Straight line conversion equation:

$$\alpha = \frac{V_{out} - Offset}{Sensitivity}$$

Where: Sensitivity = 70mV/° with SCA121T-D07 or Sensitivity= 35mV/° with SCA121T-D03 and SCA121T-D05

Tilt angle [°]	Straight line conversion error [°]
0	0
1	0.0027
2	0.0058
3	0.0094
4	0.0140
5	0.0198
10	0.0787
15	0.2185
30	1.668

## 2.3 Ratiometric Output

Ratiometric output means that the zero offset point and sensitivity of the sensor are proportional to the supply voltage. If the SCA121T-D05 supply voltage is fluctuating the SCA121T-D05 output will also vary. When the same reference voltage for both the SCA121T-D05 sensor module and the measuring part (A/D-converter) is used, the error caused by reference voltage variation is automatically compensated for.

## 3 Mechanical Specifications

Cable length:	-D03,-D07    30cm -D05            110cm
Cable type:	UL/CSA listed, PUR black
Cable diam.:	6±0.2mm
Leads:	5 x 0.14mm <sup>2</sup>
Total weight:	Approx. 60 grams
Protection class:	IP66
Housing:	Zinc casting with passivation
Mounting:	The sensor module is to be mounted on a flat and smooth surface with 2 screws, dimension M4. Mounting torque 5 ±1Nm

### 3.1 Sensor dimensions

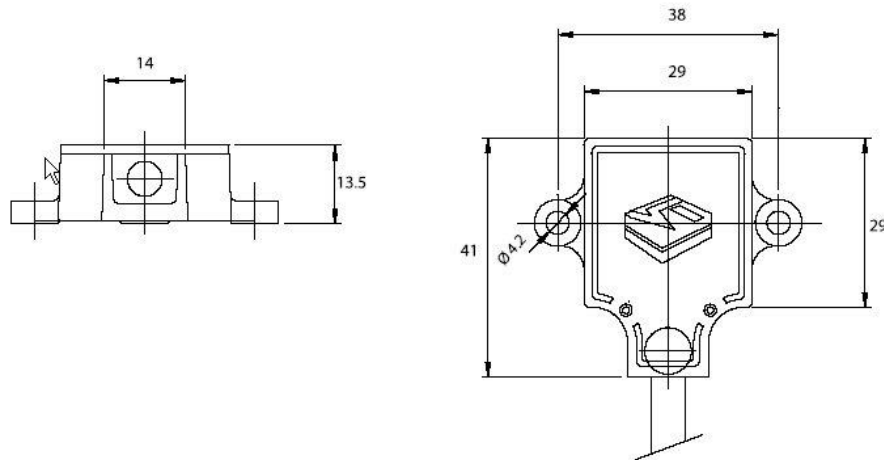

**Figure 2.** Mechanical dimensions of the SCA121T (dimensions in mm)



**IS-LINE GmbH**  
Edisonstr. 16  
85716 Unterschleißheim  
Tel.: +49 (89) 374 288 87 - 0  
Fax: +49 (89) 374 288 87 - 99  
E-Mail: [info@is-line.de](mailto:info@is-line.de)  
[www.is-line.de](http://www.is-line.de)