

<Bomi>

an experiment in advanced expression control for automated organs.
Dr. Godfried-Willem Raes



In 2008 we finished the construction of our automated 6 octave quartertone organ <Qt>. It was the output of a three-year post-doctoral research project on the extension of expressive possibilities by applying modern automation and robotic principles to traditional instrument-building practice. For the realisation of this robot, we were assisted by Ghislain Potvlieghe (organ builder) and Johannes Taelman (engineer). The research, design and realisation was in our own hands.¹ This quartertone instrument also made it possible to extend the

compositional language far into the realms of microtonality, as has been demonstrated in pieces written for it by Kris De Baerdemacker, Sebastian Bradt, Frank Nuyts, Yvan Vander Sanden, Kristof Lauwers, Barbara Buchowiec, Thomas Smetryns and myself. Together with other robots we had created previously (<Xy>, a quartertone xylophone, <Tubi>, <Puff> and the series of automated monophonic wind instruments consisting of an oboe, a sousaphone, a helicon, a saxophone and a cornet) it offers the only acoustic quartertone instrument collection in this country available for use by composers.² All our musical robots are designed to listen to and be controlled by MIDI commands.

The experience gained from the construction of <Qt> continued to intrigue us and raised quite a few new challenges. In <Qt> we achieved touch sensitivity for each pipe by driving the flat solenoid valves in the wind chest with a variable voltage. To what extent could this be improved by using conical or spherical valves? Would it be possible to fully implement aftertouch control? What would be the consequences of designing the organ to operate at very low wind pressure? Qt was designed to work with 14 mBar pressure, which is quite high by traditional organ standards. The modulation characteristics of the sound when modulating the wind pressure are very different when the nominal pressure changes. At low pressure, modulation possibilities appear to be larger.

To obtain an experiment-based answer to these questions, we set up another relatively small building project: <Bomi>, finished by the end of 2010. The design of this musical robot was triggered by an offer found on the August Laukhuff website for a semi-finished and incomplete wooden 4-foot register that seemed perfectly suitable to carry out these experiments. The stopped pipes are made of light oak wood and we made an extra five pipes ourselves, so that the lowest note is now 55 (low G). With 37 pipes in total, we obtained an ambitus of three octaves:

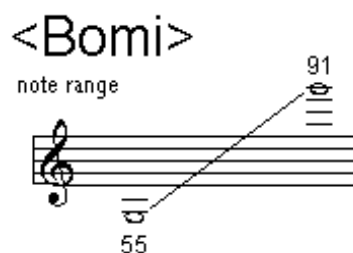

The sound was designed to be soft and gentle, but still pretty rich in overtones and with a clear and slightly spitting attack. This was achieved using traditional techniques of organ pipe intonation and tuning. To aid in adjusting the instrument we added regulating screws in the pipe feet. The wood has been left in its natural and untreated state. The pipes are tightly fitted to the wind chest using easily replaceable Teflon tape (PTFE), the same type used in general plumbing. Since the instrument is designed for transportation, the pipes are inserted deeper into the upper plate of the wind chest than usual in traditional organ building.

The scale used for the register is (scales in mm):

		internal	external	pipe length	pipe length from flue	length of foot	hole size	conical valve
note 55	g 0	37.0 x 49.0	50.0 x 63.0	460 mm	400 mm	60	10	24
note 56	g#0	35.5 x 47.0	49.0 x 61.0	435 mm	378 mm	60	10	24
note 57	a 0	33.5 x 45.0	47.0 x 59.0	414 mm	355 mm	60	10	24
note 58	a#0	33.0 x 43.5	46.0 x 58.0	392 mm	336 mm	60	10	24
note 59	b 0	31.0 x 42.0	45.0 x 56.0	370 mm	313 mm	60	10	24
note 60	c 1	29.0 x 41.0	43.0 x 54.0	340 mm	280 mm	60	9	24
note 61	c#1	28.5 x 38.7	42.0 x 50.5	324 mm	267 mm	60	9	24
note 62	d 1	27.0 x 37.5	40.0 x 50.0	305 mm	250 mm	60	9	24
note 63	d#1	26.5 x 36.0	38.5 x 48.5	290 mm	237 mm	50	8 /8.5	18
note 64	e 1	25.0 x 35.0	37.0 x 47.5	274 mm	220 mm	50	8.5	18
note 65	f 1	23.5 x 32.5	34.5 x 45.0	260 mm	210 mm	50	8.5	18
note 66	f#1	23.5 x 32.0	34.5 x 43.5	250 mm	195 mm	50	8.5	18
note 67	g 1	23.0 x 30.0	33.0 x 42.0	238 mm	185 mm	50	8.5	18
note 68	g#1	21.5 x 30.0	32.0 x 40.5	227 mm	175 mm	50	8.5	18
note 69	a 1	21.0 x 29.0	31.0 x 40.0	220 mm	170 mm	50	8.5	18
note 70	a#1	20.0 x 27.5	30.0 x 37.5	207 mm	159 mm	50	8.5	18
note 71	b 1	19.5 x 27.5	29.0 x 36.5	199 mm	151 mm	50	8.5	18
note 72	c 2	18.7 x 25.5	28.5 x 35.4	190 mm	143 mm	50	8 /8.5	18
note 73	c#2	18.0 x 24.5	28.0 x 34.5	180 mm	133 mm	40	7 / 6.5	16
note 74	d 2	17.0 x 24.0	27.0 x 34.5	175 mm	128 mm	40	6.5	16
note 75	d#2	16.5 x 22.9	25.0 x 32.0	169 mm	122 mm	40	6.5	16
note 76	e 2	15.5 x 22.0	24.5 x 31.0	162 mm	117 mm	40	6.5	16
note 77	f 2	15.0 x 21.0	24.0 x 30.0	155 mm	109 mm	40	6.5	16

note 78	f#2	14.5 x 21.0	23.5 x 29.5	150 mm	105 mm	40	6.5	16
note 79	g 2	14.4 x 19.5	23.0 x 29.0	145 mm	100 mm	40	6.5	16
note 80	g#2	13.7 x 10.2	22.0 x 28.2	138 mm	94 mm	40	6.5	16
note 81	a 2	13.4 x 18.5	21.0 x 26.3	134 mm	90 mm	40	6.5	16
note 82	a#2	12.5 x 18.0	20.0 x 26.0	128 mm	85 mm	40	7 / 6.5	16
note 83	b 2	12.2 x 17.3	20.0 x 25.0	122 mm	80 mm	40	5.5 / 5	12
note 84	c 3	11.6 x 16.0	19.8 x 24.0	120 mm	77 mm	40	5	12
note 85	c#3	11.6 x 16.0	19.0 x 23.6	114 mm	72 mm	40	5	12
note 86	d 3	10.9 x 15.8	19.0 x 23.5	109 mm	69 mm	40	5	12
note 87	d#3	10.1 x 14.7	17.0 x 21.5	104 mm	64 mm	40	5	12
note 88	e 3	9.8 x 14.0	16.5 x 21.0	102 mm	61 mm	40	5	12
note 89	f 3	9.0 x 14.0	15.5 x 20.5	98 mm	57 mm	40	5	12
note 90	f#3	9.0 x 13.0	15.5 x 19.5	95 mm	55 mm	40	5	12
note 91	g 4	9.0 x 12.5	15.5 x 19.3	91 mm	50 mm	40	5	12

The size of the wind chest upper plate in light oak-wood is 760mm x 240mm x 45mm. The pipes are arranged in two rows, with the first row holding pipes 69 to 91 and the back row notes 55 to 68. The wind flow to each pipe is controlled inside the wind chest with solenoid-driven conical electrical pallets. Conical valves allow for a much better airflow regulation than the flat pallet valves we had used hitherto.

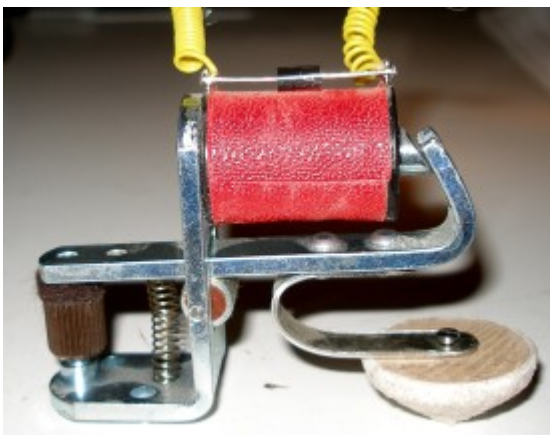

Thanks to these valves, we obtained velocity sensitivity for each individual note as well as individual key pressure modulation (note aftertouch). The sizing of the pallet valves with conical pads is given in the table above. These sizes were calculated such that for a given solenoid trajectory (5 to 10mm) and orifice, flow regulation is optimal. We designed software to calculate the

frustum shaped apertures based on the following geometric considerations³:

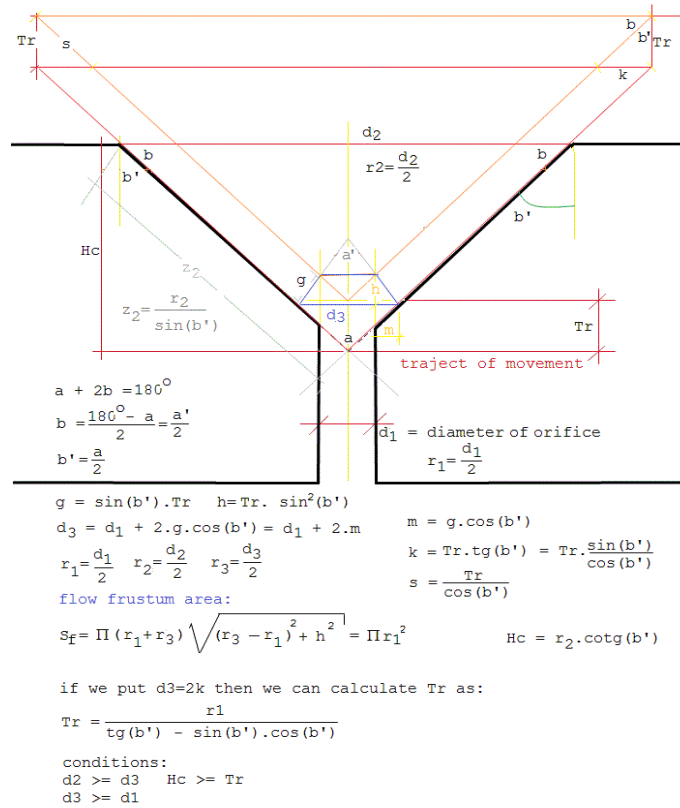

Calculated results for Bomi:

cone diameter	top angle	trajectory	diameter of equivalent orifice
35mm / 15mm	110°	5.2mm	10 mm
25mm / 12mm	100°	5.0mm	7 mm
20mm / 11mm	85°	6.0mm	5 mm
16.5mm / 10.2mm	81°	6.0mm	4.3 mm
13mm / 8.7mm	72°	6.0mm	3 mm

For cones with a top angle of 90 degrees, the trajectory will always equal the orifice. An easy rule to keep in mind. The top angles were not a freely chosen parameter, since we used ready-made cones from Laukhuff. The main problem we met here was the milling of the exactly shaped conical holes in the wind chest. This led us to order custom-made mills, a pretty expensive undertaking...

In order to make it possible to adjust the valves in the wind chest without having to remove all the pipes, we constructed the pipe holder above the wind chest in such a way that it can be lifted up mechanically. Moreover, even without lifting the pipe holder, the mechanical parts can be accessed through the polycarbonate windows in the front and back of the wind chest. It should be noted here that the leak-free adjustment of the conical valves is a whole lot more difficult to perform than if we had used flat pallets. We had to design and make quite a few special spring-bending tools to complete this task to our satisfaction:



The electric connection between valves and steering electronics makes use of a series of Weidmueller connectors leaving the pipe holder through a vertical hole and an airtight cable gland.

Global wind pressure control is possible over a wide range, although as can be expected from flue pipes, tuning cannot be guaranteed under extreme deviation from the normal pressure circumstances. The global pressure control is mapped on midi controller 7, as it is related to the sound volume. The maximum wind pressure is 65 mm water column (= 6.5 mbar) and generated by a small 70 Watt Laukhuff Ventola-type organ blower driven by a programmable 3-phase motor controller from Siemens. Air production is 1 cubic meter a minute. Normal working pressure should be 45 mm water column (4.5 mbar). Tuning is pretty much stable in the range 40 to 50 mm H₂O.

A tremulant, using a softshift solenoid valve⁴ on the wind inlet in the wind chest, is also part of the design. Its operation can be seen as we have made the wind chest transparent. The softshift valve used here to steer a large conical valve can be controlled with midi controller 1; however its function is inverted such that for controller value zero, the valve will be fully opened and for value 127 fully closed. The "all notes off" command (controller 123) always resets this valve to the fully opened state. The valve can very well be used for fast-responding dynamic control as well as for inflections affecting all sounding pipes.



The entire circuitry for this robot makes use of three fast PIC controllers: Microchip PIC18F4625 - I/SP types. For each group of 14 notes, a controller takes care of the midi input parsing and the note on/offs, mosfets and conical valve solenoids. There is precise control over the note attack (the velocity byte accompanying each note on command controlling the response speed of the valves) as well as over wind flow

modulation during the sounding of a note. This is implemented with polyphonic midi note aftertouch commands and, on the processor level, by applying slow PWM to the hold voltages over the solenoids.

This is the principle:

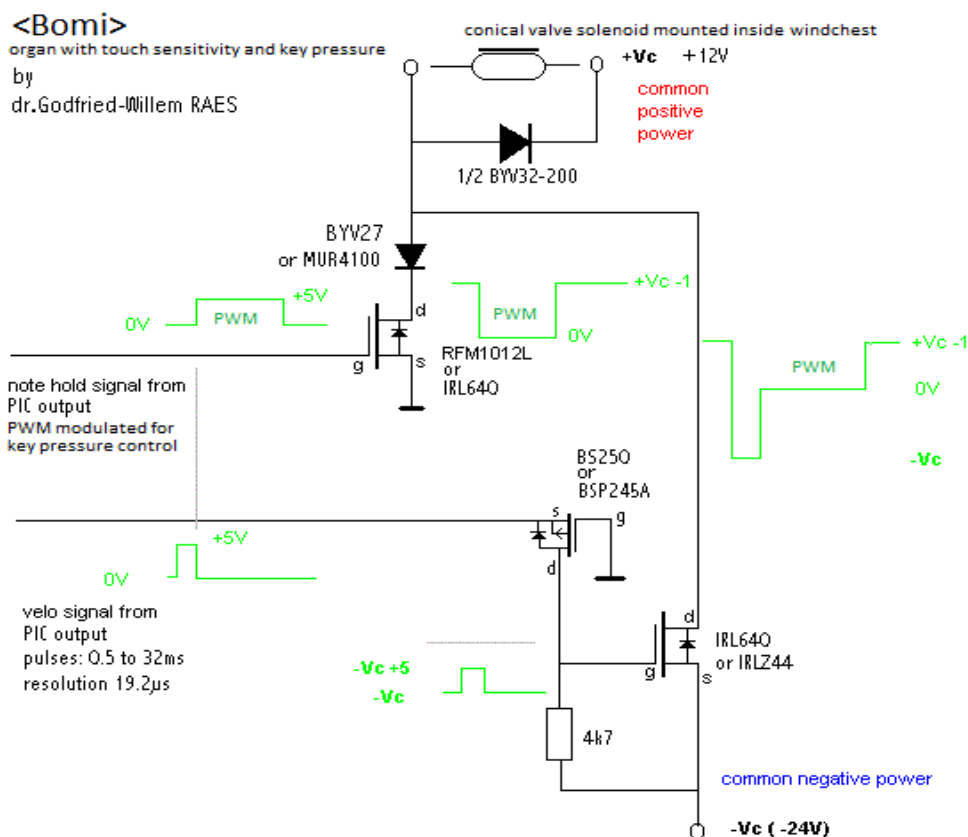

It is important to the user to know that the velocity byte in the midi note-on command does not control sound volume, but only the way the pipes begin sounding. It is strictly an attack control. For detailed circuitry and board population, please refer to the web page of our [<harmO>](#) robot, since it uses the same boards. The PIC firmware however is very different, since we implemented the PWM steering here required for the key pressure control. A fourth PIC micro-controller (a 18F2525 type) takes care of the steering of the wind valve / tremulant as well as the motor commands and the PWM for the 3-phase motor controller.

A manometer on the wind chest allows for easy and precise adjustment of wind pressure in function of tuning operations. A thermometer is mounted permanently inside the wind chest, to make it possible to know the exact operating conditions. One should not forget that the compression of air always results in an increase of temperature, and since pipe pitch depends on the temperature of the wind, it becomes an important design parameter.

The robot was build as an autonomous module with a chassis made from welded stainless steel and placed on wheels for easy transportation.

Midi implementation:

The midi channel for <Bomi> is 3 (0-15).

Midi note range: 55 - 91. (c-g"), velocity implemented (steers the speed at which the valves open and hence the note attack). The lights added as an extra feature are mapped to the note range 120-125.

Note Off commands are required.

Controller #66 is used to switch the motor on or off.

Controller #1 is used for the wind valve: at value 0 it is fully opened, at 127 it is fully closed. Thus by default and after reset the valve will always be opened. The tremulant is implemented as a modulation around the position of the wind valve as set by controller 1. Default value for controller 1 when using the tremulant: 80. With high modulation depth (controller #12) it should be smaller.

Controller #11 controls the speed of the tremulant. Normal values are between 100 and 110. Modulation depth can be controlled with controller #12. Default value 60. This is the excursion the valve will make around the central position as set by controller 1. More gentle effects are obtained by setting this controller to 38 (with CC11 to 100 and C1 to 90). Note that tremulant speed, depth and wind valve position interfere with each other and not every combination of values will work well.

Controller #7 is used for the wind pressure (motor speed). The normal setting should be 72. Default start-up value in the PIC firmware is 0. It cannot be used for fast wind pressure modulation but is perfectly suitable for slow crescendo en decrescendo. Note however that pitch as well as intonation may be affected when Bomi is operated at non-standard wind-pressures.

<Bomi> responds to the midi all-notes-off command. This command also

switches off the lights and the wind valve, but not the motor. To switch off the motor, controller #66 should be used.

Technical specifications:

- size: 820 x 330 x 1230 mm. (w x d x h)
- weight: approx. 50 kg
- power: 230V AC - 286W(peak)
- Tuning: based on A = 440 Hz at 21° Celsius ambient.
- static wind pressure in the wind chest for normal tuning and intonation: 45 mmH₂O or 4.5 mbar
- Sound pressure level: max. approx. 84 dBA, motor background noise <= 42 dBA. (Measured under normal operating conditions at 1 m distance)

Concluding evaluation:

Since its finalisation, many composers have used <Bomi> as a much welcomed sound in the robot orchestra. The robot was also demonstrated at the festive opening of the STAM museum for over 20000 visitors. Demonstration audio recordings are available from our website. Due to its flexibility in tone production and modulation, <Bomi> is extremely well suited to real-time interactive playing using our gesture sensing and recognition system. This was convincingly demonstrated in our Namuda studies, a collection of interactive compositions⁵. Study #7 ('RoboBomi') was written for a dancer, the gesture system and <Bomi>. These pieces are performed regularly on the concerts of the M&M robot orchestra at Logos in Ghent.

Bibliography:

RAES, Godfried-Willem "Expression control in automated musical instruments", a paper presented at the NIME conference, New York 2007. Last updated 01.2011. Weblink: http://www.logosfoundation.org/g_texts/expression-control.html

RAES, Godfried-Willem "NaMuDa: gesture recognition for musical practice" , a paper presented at the ThinkTank, IPEM, Ghent 05.2010. Weblink: http://www.logosfoundation.org/ii/namuda_123.pdf

Notes:

- 1 A complete report on the design and construction of the <Qt> robot can be found at: http://www.logosfoundation.org/instrum_gwr/qt.html
- 2 A composers manual on the full robot orchestra -nowadays consisting of 47 robots- is available at: http://www.logosfoundation.org/instrum_gwr/manual.html
- 3 To facilitate comparative calculations, we have also worked out the maths for flat valves:

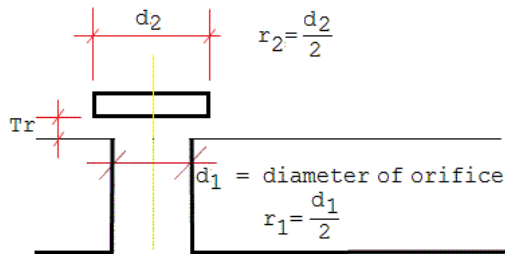

Tr = trajectory of movement

$$Tr \leq \frac{r_1^2}{d_1} = \frac{r_1}{2} \quad d_2 \geq 3 \cdot r_1$$

flow area: $\pi r_1^2 = 2\pi r_1 \cdot Tr$

The results prove the superiority of conical valves but also make clear that for trajectories in the order of 4 to 8 mm, the use of conical valves on very large orifices would not be appropriate. For instance, they would not have been a good choice on the lowest pipes of our <Qt> robot.

- 4 Vertical softshift solenoids for expressive wind pressure modulation mounted inside the wind chest: Ledex Softshift type 5EP (now Saia Burgess), number 193015-026. Cold DC resistance 10.3 Ohm. Nominal working voltage at 100% duty cycle: 14 V.

14 V (force = 8 Newton), Current 1.36 A, Power = 19 W
 at 50% (force = 18 Newton) , 20 V, 2 A, P= 40 W
 at 25% (force= 30 Newton) , 28 V, 2.7 A, P= 75 W
 at 10%, 44 V (force= 50 Newton) , 4.3 A, P= 190 W
 Price (this is not a joke): 144 USD a piece at qty= 10 ...

For the working of this valve, taking into account the very low air pressure (normally 4.5 mbar, maximum 7.0 mbar), a voltage of 12 V is enough. The valve starts opening with a voltage of 2.6 V and is fully opened with 11 V.

- 5 The collection of Namuda studies is an ongoing composition project. It is documented at: http://www.logosfoundation.org/scores_gwr/namuda_links/namuda.html